

Wanesy Wave

« A LoRaWAN™ multi-technology tracking anchor to count and monitor Wi-Fi and/or Bluetooth assets in real time for facility management and industry applications»

Key Features

- Combination of Wi-Fi and BLE tracking technologies
- Wi-Fi Probe Requests collection
- BLE asset scanning and zoning
- LoRaWAN™ backhauling
- Scanning, counting and zoning embedded application
- Certification: CE (EU868) and FCC (US915)



Indicators examples

- “How many people or assets are in that specific area?”
- “How many people or assets have been in that area for 10 minutes or 1 hour?”
- “Which are the new assets within the last 10 minutes?”
- “What is the list of assets in that area?”
- “In which area is this specific asset?”

End-to-end solution



Hardware Architecture

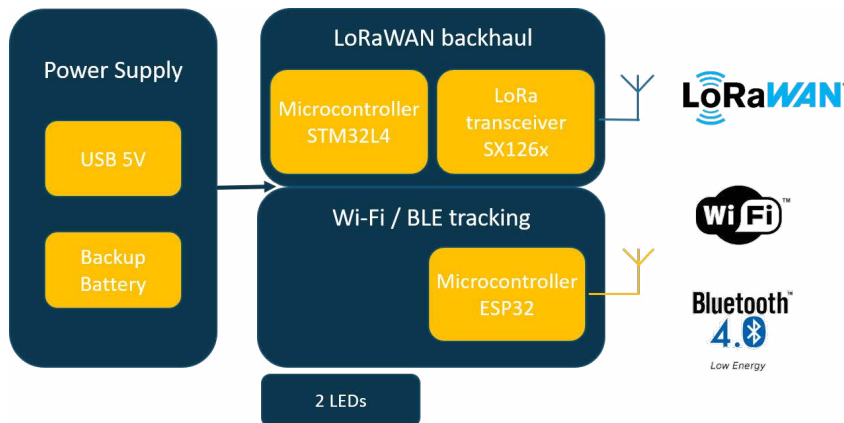

Technical features

- Characteristics:
 - Operating Temperature: -20°C to +55°C
 - Size: 100 x 75 x 22 mm
 - Ingress Protection: IP30
 - Weight: < 200g
 - Two status LED (1 green/1 red)
- Power supply:
 - USB Micro-B connector (5VDC)
 - Internal backup battery (1mAh)
- Wi-Fi:
 - 802.11 b/g/n/e/l
 - Probe Requests collecting
- Bluetooth:
 - V4.0 BR/ Bluetooth Low Energy
 - BLE scan / iBeacon
- LoRaWAN:
 - EU868 (SX1261) with TX up to 15 dBm
 - US915 (SX1262) with TX up to 22 dBm

Product Ordering References

- PDTIOT-WAV02 Wanesy WAVE 868
- PDTIOT-WAV03 Wanesy WAVE 915 & 923

Accessories

- ACCIOT-WAV00 : Interchangeable blades AC-DC-5V-1A power supply
- KLK03544: Splitter POE

Ask us for more information!